

Magnetic Field Sensor and Analog Front End for Medical Position Tracking

Abstract:

Electromagnetic tracking (EMT) is a key enabling technology for image-guided medical interventions. Commercial EMT systems enable catheter, neurosurgery and flexible endoscopy tool tracking. However there are shortcomings with current solutions viz. large coil-based sensors, susceptibility to noise and interference, large system latency etc. This project will implement a SoC solution to address many of these shortcomings. Mixed-signal ASIC/SoC benefits include: smaller devices, better accuracy, wireless integration, faster systems and reduced noise.

Introduction:

We are proposing to develop a new SoC Receiver architecture with focus on the following novelties:

- First CMOS-based EMT implementation platform suitable for endoscope integration
- First integrated inductive sensor suitable for <1mm tracking applications
- First integrated high-resolution ADC for low-latency read-out of sensor voltage
- 4X improvement in accuracy and noise suppression compared to discrete coil
- 10x improvement in system latency compared to current commercial and clinical systems through minimal transmission delays, single-die implementation enabling near real-time tracking (not possible with current 30-40ms latency in commercial OEM platforms such as NDI Aurora). Very important for robotic surgery integration
- Significantly reduced EMI susceptibility through integrated inductive loops and on-chip calibration for noise compensation.

The Receiver will consist of an integrated magnetic sensor coil, analogue signal filtering & conditioning, 16-bit ADC for digital signal conditioning, 1 mm² package SoC solution for immediate integration and testing with Anser. We aim to use standard 65nm TSMC General Purpose processes and integrated Ferric for CMOS BEOL integrated magnetic material.

Target Specs:

- Magnetic field sensitivity ~ 1 mV/T (voltage mode sensing)
- Sensor bandwidth < 100 kHz
- AFE: min detectable signal 1uV
- IC area: Height < 0.5mm, Width <5mm

System Architecture:

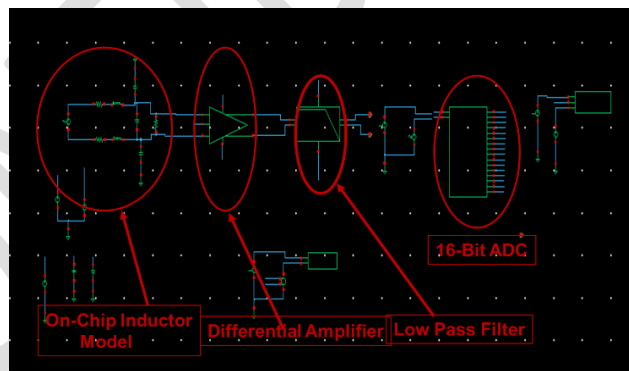

Figure 1. ANSER Receiver Architecture

Results to Date:

On Chip Inductor Modelling:

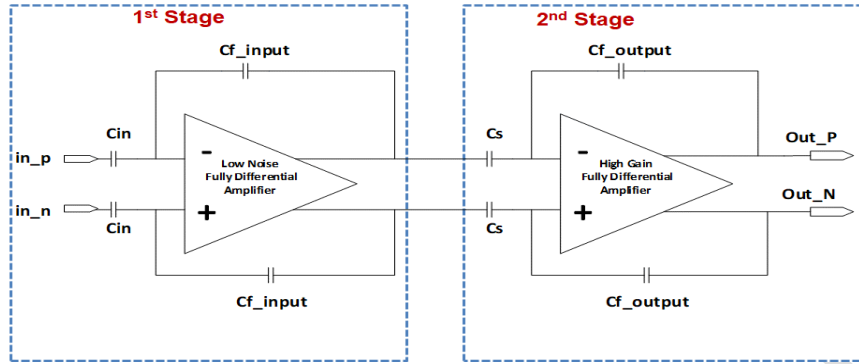

Figure 2. Our 2-stage amplifier configuration is designed to minimize noise using fully differential capacitive feedback on both stages.

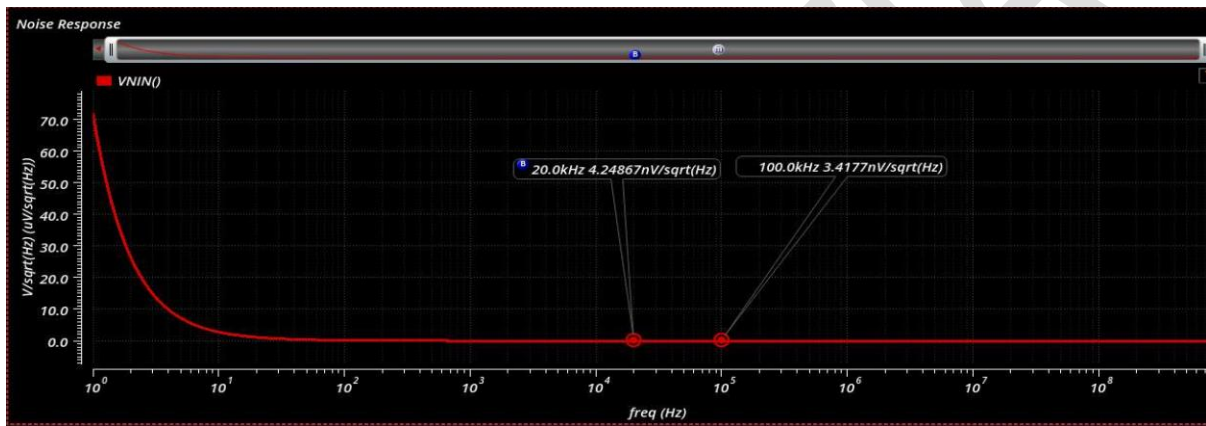

Figure3. Noise Simulation Results for FE Low Noise Amplifier

Input Frequency(KHz)	Spec Noise Density(nV/ \sqrt{Hz})	Measured Noise Density(nV/ \sqrt{Hz})	Spec Flicker Noise Corner	Measured Flicker Noise Corner
20	2	4.2	<10KHz	9KHz
100		3.41		

Table 1. Noise Simulation Results for FE Low Noise Amplifier

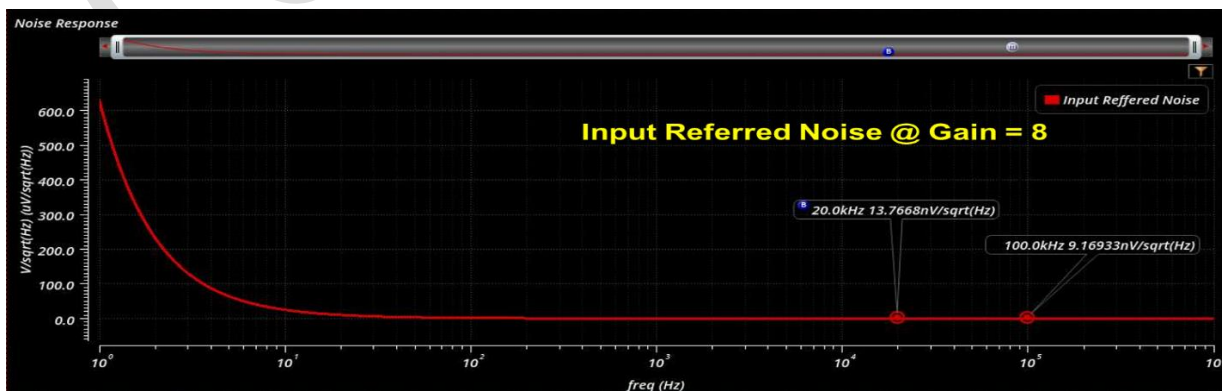

Figure4. Noise Simulation Results for 2nd Stage Programmable Amplifier

Input Frequency(KHz)	Spec Noise Density(nV/\sqrt{Hz})	Measured Noise Density(nV/\sqrt{Hz})	Spec Flicker Noise Corner	Measured Flicker Noise Corner
20	10	13.7	<10KHz	13KHz
100		9.1		

Table2. Noise Simulation Results for 2nd Stage Programmable Amplifier

Observation: The flicker noise from Differential pairs is main contributor towards total input referred noise of FE Low noise amplifier.

Amplifier Specifications:

Spec Name	Min	Typ	Max	Simulated Results
Input Referred Noise		$2nV/\sqrt{Hz}$		$4.2nV/\sqrt{Hz}$
Power			6mW	
Offset				
Flicker Noise Corner		<10KHz		9KHz
Area		$360 \times 320 \mu m^2$		
Input Voltage(P-P)	1uV		1mV	
Output Voltage Swing (P-P)	20uV		20mV	
Gain (Vo/Vi)		20		
PSSR		-50dB		-42dB
CMMR		-50dB		-52dB
Power Supply		1.2		
Signal Frequency		20KHz	100KHz	
Input Common Mode		0V		
Output Common Mode		600mV		
PM		60°		75°

Table 3. FE Amplifier specifications on full system simulations.

Spec Name	Min	Typ	Max	Simulated Result
Input Referred Noise@20KHz		$10nV/\sqrt{Hz}$		$7.08nV/\sqrt{Hz}$
Power		4mW		4.9mW
Output Offset		50mV		
Flicker Noise Corner		10KHz		13KHz
Area				
Input Voltage(P-P)	3uV		20mV	
Output Voltage Swing (P-P)	120uV		0.8V	
Gain (Vo/Vi)	8		40	
PSSR@100KHz		-50dB		-191dB
CMMR@100KHz		-50dB		-210dB
Power Supply		1.2		
Signal Frequency		20KHz	100KHz	
Input Common Mode		150m		
Output Common Mode		600m		580m
Programmable Gain Fully differential Amplifier PM		50°		86°

Table 4. 2nd Stage Programmable Amplifier specifications on full system simulations.

Transient Noise Analysis Results:

- Input Signal : 1mV(P-P) @100khz
- FE Amplifier Gain = 20
- 2nd Stage Amplifier Gain = 8
- Switch(Duty Cycle Resistor) frequency : 250KHz
- Auto Zero Switch Frequency : 3KHz
- Sampling Frequency : 13MHz
- No of Samples : 131072
- BW = 100 Hz

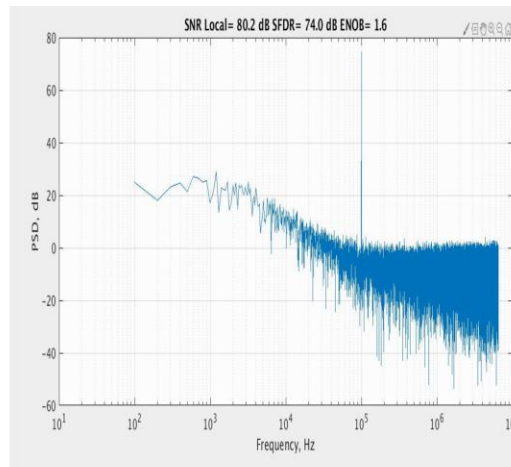

Figure 5. Transient noise simulation result on full system simulations.

We have taped out 4 Chips variants in June 2020.

Chip	Inductor	FE Amplifier	2nd Stage Amplifier	Comment
A	M8(117 Turns)	Gain Boost	Gain Boost	
B	M9(38 Turns)	No GB	NO GB	
C	M9(38 Turns)	Chopping	Gain Boost	
D	M8(40 N) + M9(37 N) + M10 (22 N)	Gain Boost	Gain Boost	Debug Version Pin Out for Inductor and amplifier

PCB design has been completed and sent for fabrication.

Silicon Testing

- Post Silicon, all chips variants have shown short between avdd & avss pins.
- These shorts were caused by ESD events during dicing as the ESD protection didn't work correctly.
- Initial measurements of the sensor are good and tracking has been demonstrated using an external amplifier

➤ **New LNA Design Completed**

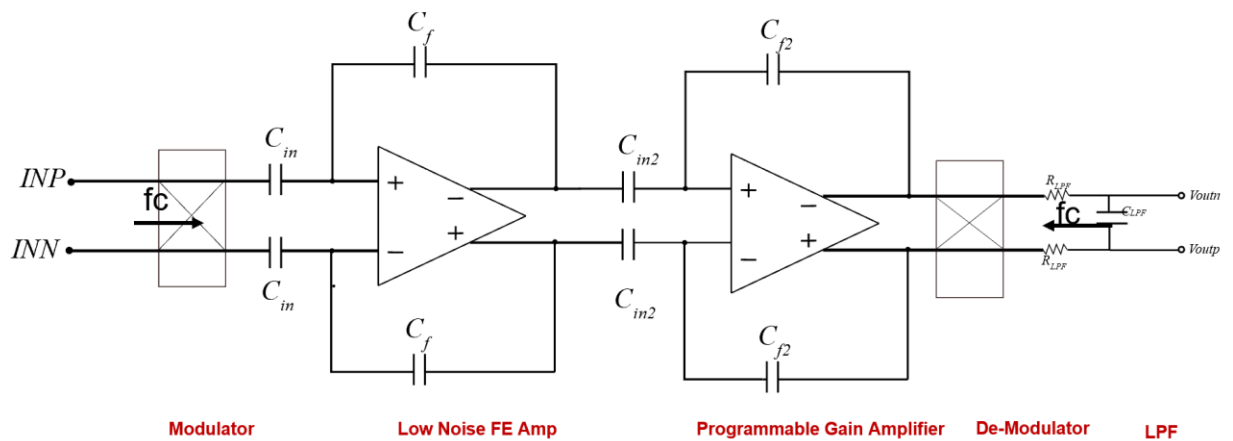

Figure 6: New LNA Architecture

➤ **Result to Date**

Spec Name	Min	Typ	Max	Measured
Input Referred Noise		$<1n \text{ V}/\sqrt{Hz}$		$1.47n \text{ V}/\sqrt{Hz}$
Power			5mW	5.2mW
Offset				
Flicker Noise Corner		$<1KHz$		300Hz
Area		$350 \times 800 \mu m^2$		
Input Voltage(P-P)	120n	1 μ	1m	
Output Voltage Swing (P-P)	120u		200mV	
Gain (Vo/Vi)	200		1000	
PSSR		-50dB		-42dB
CMMR		-50dB		-56dB
Power Supply(avdd)		1.2V		
Power Supply(IOVDD)		2.5V		
Signal Frequency	2KHz	20KHz	100KHz	
Input Common Mode		0V		
Output Common Mode		600mV		600mV
PM		60°		75°

Table 5. Top Level Amplifier specifications on full system simulations

• **Silicon Results**

- The improved ESD design produced better results, with no ESD events occurring during chip testing.

○ Noise Result

Noise measurement @ 10kHz	Gain	Chopping (500kHz)	Simulated	Measured
Input Referred Noise (nV/sqrtHz)	min	off	5.8	5.04
Input Referred Noise (nV/sqrtHz)	Max	off	4.2	3.86
Input Referred Noise (nV/sqrtHz)	min	on	2.35	2.49
Input Referred Noise (nV/sqrtHz)	Max	on	1.588	1.25

○ CMRR Result

	Simulated	Measured
CMRR(dB) @ 10kHz	82.6	81.7

○ PSRR Result

	Simulated	Measured
PSRR(dB) @ 10kHz	-43.8	-40.8

○ Tracking Accuracy Result (ANSER on-chip vs existing solutions)

Device	FG Type	Acc.(mm)
NDI Aurora	Planar	0.8
	Tabletop	0.3
	Compact	0.5
Ascension micro Bird	Mid Range	0.69
Ascension 3D guidance	Mid Range	0.24
	Flat	0.18
ANSER EMT	Planar	1.14
ANSER EMT On-Chip	Planar	1.3(This work)

Next Steps:

- Continuous Time Delta Sigma ADC design

Tape out of ADC with current sensor and analog front-end by April 22

- Patent & Paper Writing